

Arete Stone Kitchen Sink

SKU: TWM-NBD150 / TWM-NBD150W

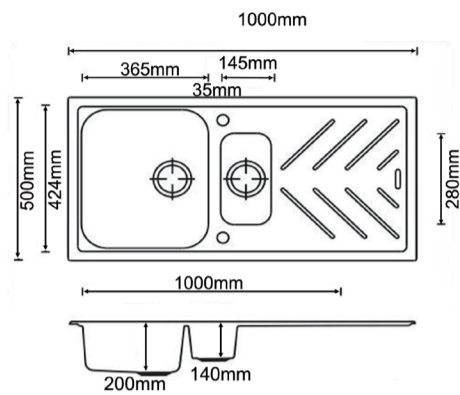
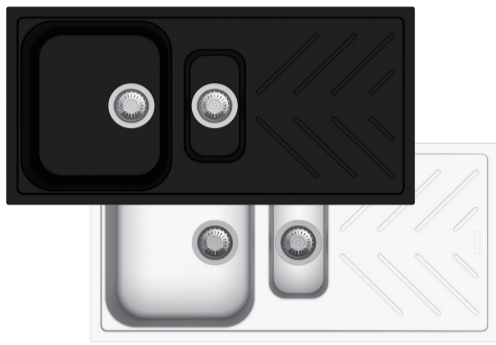

www.aquaperla.com.au

SPECIFICATION

Color Availability: White / Black

Material: Granite

Dimension: 1000mmL x 500mmW x 200mm

Weight: 20.00KG

Package Size: 1100*600*300 mm

Spec.: Arete Stone Kitchen Sink

Installation: Top-mount

Instructions for Top Mounted Sinks

<p>①</p> <p>POSITION SINK ON WORKTOP</p>	<p>②</p> <p>MARK SINK OUTLINE (LINE A)</p>	<p>③</p> <p>CAREFULLY REMOVE SINK</p>	<p>④</p> <p>MARK LINE 'B' 10MM INSIDE THE SINK OUTLINE (LINE A)</p>	<p>⑤</p> <p>CUT THE SINK CUTOUT TO THE INSIDE OF LINE 'B'</p>
<p>⑥</p> <p>SEAL THE CUT SURFACES</p>	<p>⑦</p> <p>FIT GASKET TO SINK ENSURING DOUBLE THICKNESS AT THE CORNERS AND / OR USE SILICONE SEALANT TO ENSURE GOOD SEAL</p>	<p>⑧</p> <p>PUSH CLIPS ONTO RAIL</p>	<p>⑨</p> <p>ROTATE CLAW UNDER WORKTOP</p>	<p>⑩</p> <p>LIGHTLY TIGHTEN ALL CLIPS. FINALLY TIGHTEN ALL CLIPS IN ORDER SHOWN</p>

Instructions for Under Mounted Sinks

<p>1</p> <p>You can mount the product on your own. It is recommended, however, that 2 persons participated in the measuring and alignment works requiring precision. Always wear protective glasses and gloves throughout the assembly.</p>	<p>2</p> <p>Draw a cutting line with a pencil on the worktop by the help of the instruction packed which have shown the cut-out dimension. The recommended minimum distance from the edge of the opening to the edge of the worktop is 50mm.</p>	<p>3</p> <p>Cut the sinking opening with a suitable tool in the worktop along the dashed line. Determine location for mounting bracket, space evenly around the underside, mounting holes should be 13mm out from the edge of the sink ledge. Knock the plastic expansion screw into the mounting hole.</p>	<p>4</p> <p>Apply a bead of caulk about 3mm-5mm away from the edge of the counter cutout and then align sink on counter. Caulk not included. Consult to your professional installer.</p>
<p>5.1</p> <p>A Counter / benchtop Sealant Sink flange Support board with routed edge (such as timber)</p> <p>Sandwich method for thin and thick benchtops:</p> <ol style="list-style-type: none"> 1) Cut out the sink hole according to the support board. To make the sink flange sit above the edge of the support board. 2) Route out the edge of the support board slightly with a router, then the edge of the sink will sit flush with the top of the support board. Notch the support board around the location of any clip brackets where applicable. 3) Test the support board before sealing into place. 4) Install sink and seal between flange of sink and support board. 5) Seal the underside of the bench top and the support board. 6) Fasten the support board to the underside of the bench top using high strength epoxy compound. 	<p>5.2</p> <p>B Counter / benchtop Sealant Sink flange Epoxy</p> <p>Bond method for minimum bench thickness of 25mm: Bond the sink flange to the underside of the bench top using high strength epoxy compound.</p>		

CLEANING RECOMMENDATIONS

This product should not be cleaned with abrasive materials. Damage caused by any improper treatment is not covered by the product warranty - refer to Warranty Conditions on our website: www.aquaperla.com.au

Disclaimer: Products in this specification manual must by regulation, be installed by licensed and registered trade people. The manufacturer/ distributor reserves the right to vary specifications or delete models from their range without prior notification. Dimensions are nominal measurements only. Dimensions and set-outs listed are correct at time of publication however the manufacturer/ distributor takes no responsibility for printing errors.